

LATERAL PLAN

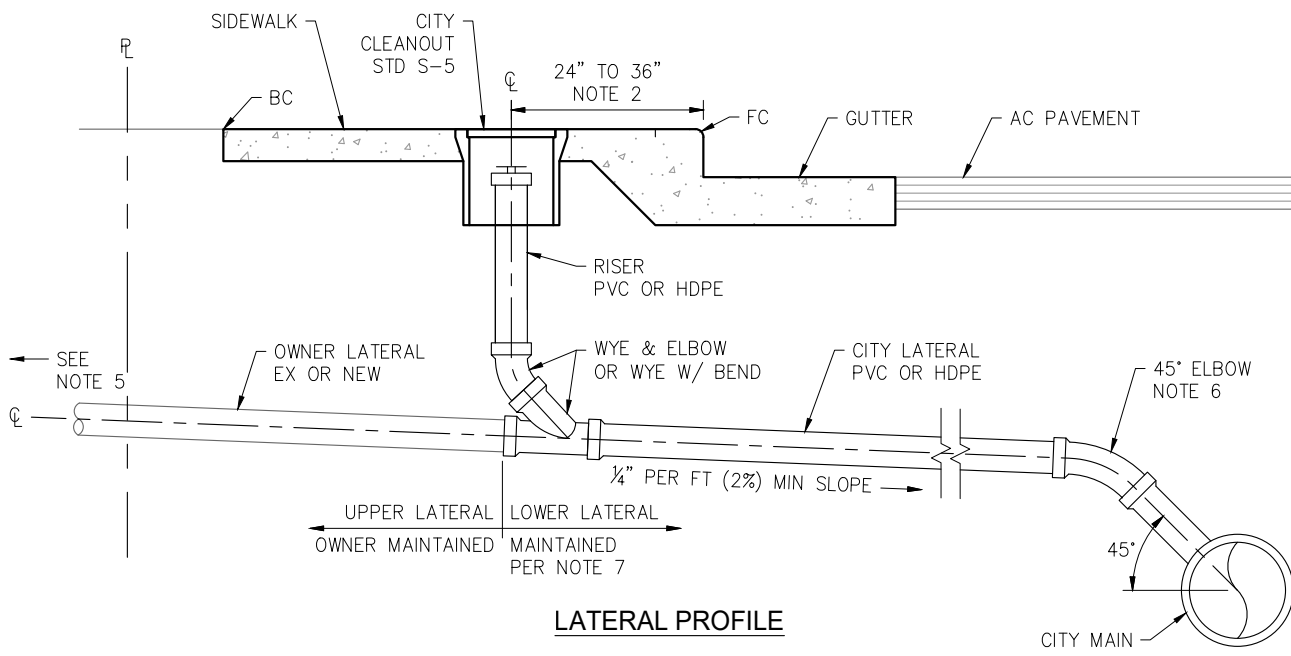

LATERAL PROFILE

NOTES:

1. LATERAL CONNECTION TO CITY MAIN SHALL BE VIA A WYE FITTING OR NEW MANHOLE ONLY. TAP OR SADDLE CONNECTIONS ARE NOT ALLOWED. MANHOLES ARE REQUIRED FOR LATERALS 8" OR LARGER.
2. INSTALL CLEANOUT CENTERED IN THE SIDEWALK PANEL CLOSEST TO THE CURB OR 24" TO 36" FROM THE FACE OF CURB.
3. SIDEWALK, CURB, AND GUTTER SHALL BE RESTORED ACCORDING TO CITY STANDARDS. SAWCUTS SHALL BE MADE AT THE EXISTING JOINTS. PARTIAL SIDEWALK PANEL SAWCUTTING/REMOVAL IS NOT ALLOWED.
4. PAVEMENT SHALL BE RESTORED ACCORDING TO CITY STANDARDS.
5. THE SEWER LATERAL SHALL INCLUDE A BUILDING CLEANOUT APPROXIMATELY 2-FT FROM THE BUILDING AND A BACKWATER VALVE SHALL BE INSTALLED WITHIN THE PROPERTY.
6. WHERE SEWER MAIN INVERT ELEVATION IS OVER 60" FROM THE SURFACE, VERTICAL BEND SHALL BE REQUIRED.
7. PER SSF MUNI CODE 14.14.040, SEWER LATERAL MAINTENANCE IS THE RESPONSIBILITY OF THE PROPERTY OWNER UP TO THE SEWER MAIN. AFTER INSTALLATION OF A CLEANOUT AND ACCEPTANCE BY THE PUBLIC WORKS INSPECTOR, A CERTIFICATE OF COMPLIANCE WILL BE GRANTED FOR A CERTAIN DURATION PER THE CODE. THE CITY WILL MAINTAIN THE SEWER LATERAL FROM THE CITY CLEANOUT TO THE MAIN, KNOWN AS THE "LOWER LATERAL" FOR PROPERTIES THAT HAVE AN ACTIVE CERTIFICATE OF COMPLIANCE.