

THIS DRAWING IS IN SUPPLEMENTAL TO THE
SSF MUNI CODE 19.20 STREET DESIGN SECTION

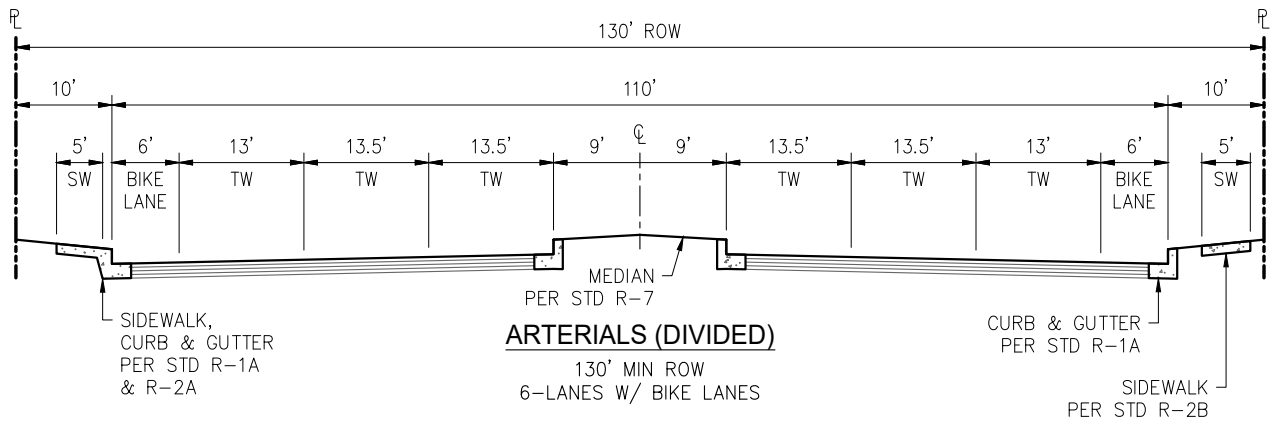
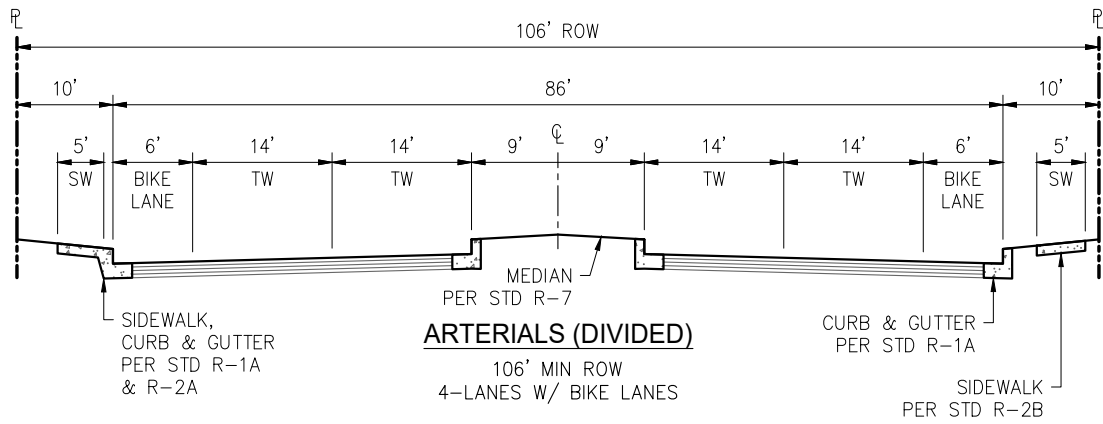
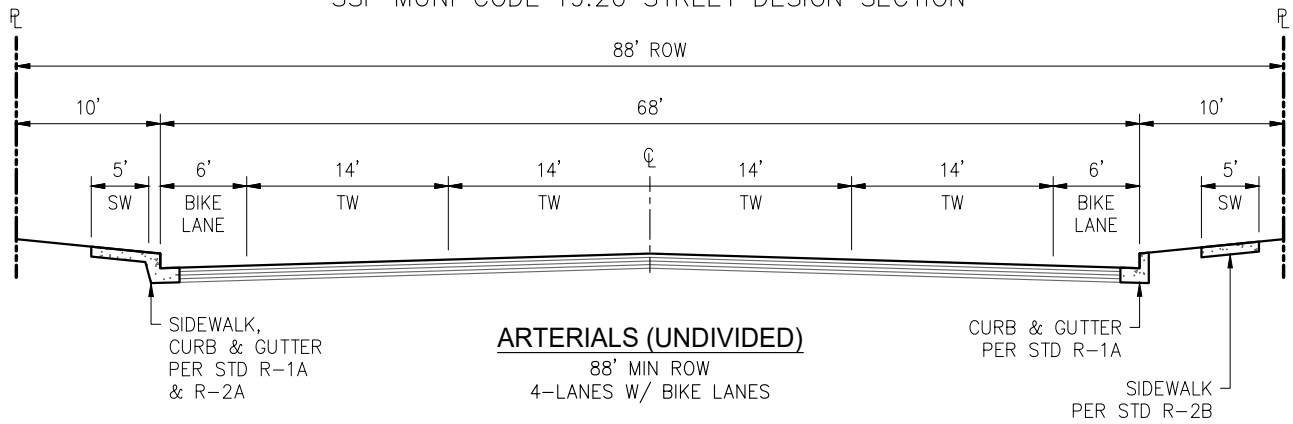

NOTES:

1. CITY STANDARD TRAVEL LANE WIDTH IS 12' MINIMUM. WHERE ROW WIDTH IS LIMITED, A REDUCTION TO 11' OR 10' MAY BE GRANTED WITH CITY ENGINEER APPROVAL.
2. TRAVEL WAY MAY BE REDUCED TO ALLOW FOR BIKE LANES WHERE ROW WIDTH CAN ACCOMMODATE.
3. CITY STANDARD PARALLEL PARKING STALL WIDTH IS 8'.
4. CITY STANDARD BIKE LANE WIDE IS 6' AND 5' MINIMUM. STANDARD TWO-WAY BIKEWAY WIDTH IS 10' AND 8' MINIMUM.
5. CITY STANDARD SIDEWALK WIDTH IS 5' MINIMUM. STANDARD SHARED-USE PATH WIDTH IS 10' MINIMUM.
6. BOTH MONOLITHIC AND SEPARATED SIDEWALKS ARE SHOWN FOR REFERENCE. STREETS MAY HAVE MATCHING TYPES OR ONE OF EACH TYPE ON EITHER SIDE OF THE STREET.
7. VARIANCES AND DESIGN DEVIATIONS REQUIRE CITY COUNCIL APPROVAL.