



DEPARTMENT OF ECONOMIC
AND COMMUNITY DEVELOPMENT
BUILDING DIVISION

RESIDENTIAL WATER HEATERS

New or Replacement
2019 California Plumbing Code

Non storage type water heaters may require the existing gas piping to be evaluated due to higher cubic feet per hour (CFH) gas demand of the water heating appliance. The vent may also require evaluation due to appliance type and manufacture venting requirements.

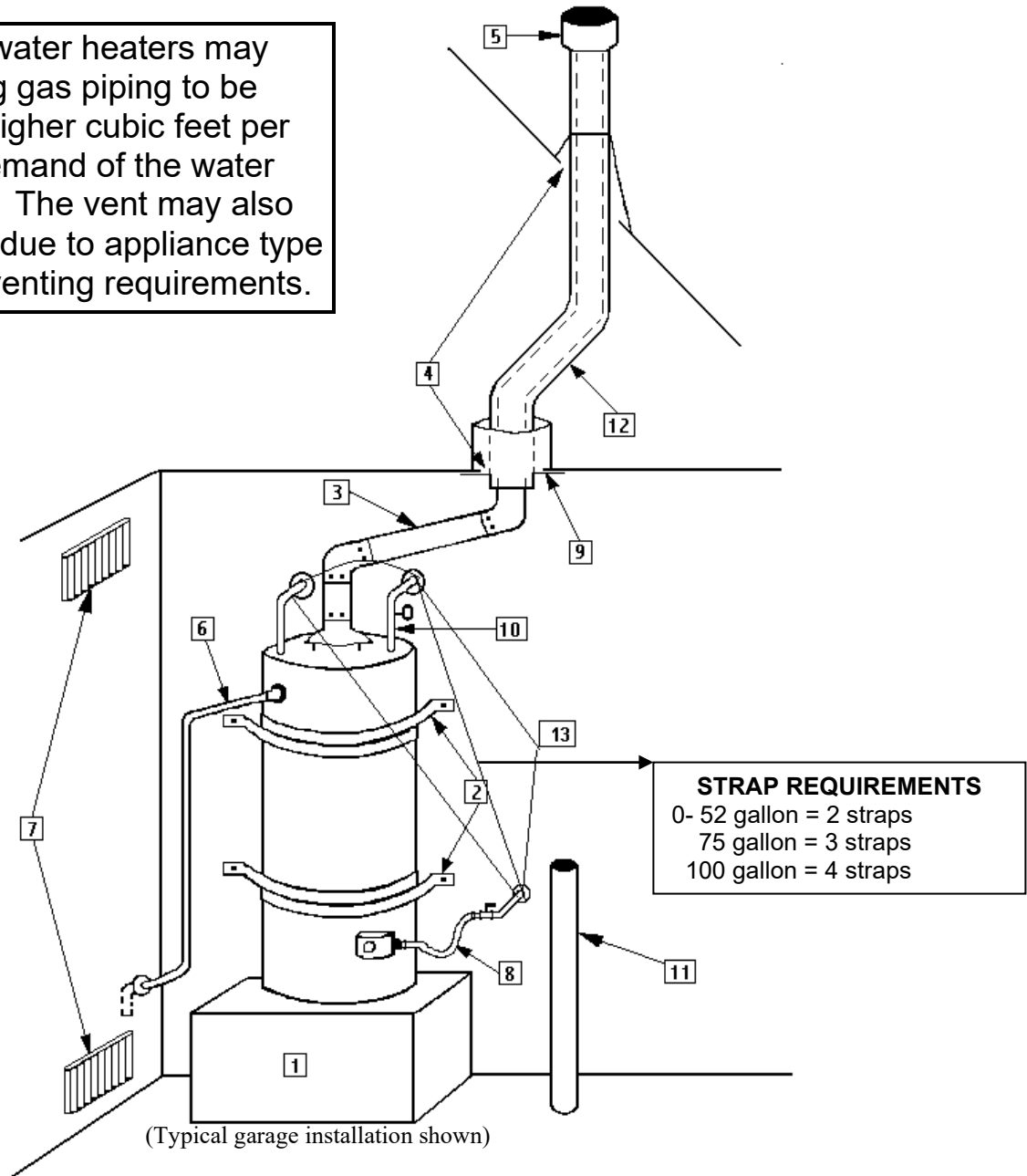

TABLE 501.1 ¹ FIRST HOUR RATING											
Number of Bathrooms	1 to 1.5			2 to 2.5				3 to 3.5			
Number of Bedrooms	1	2	3	2	3	4	5	3	4	5	6
First Hour Rating, ² Gallons	38	49	49	49	62	62	74	62	74	74	74
Note: ¹ The First- hour rating is found on the "Energy Guide:" label. ² Solar water heaters shall be sized to meet the appropriate first hour rating as shown in the table.											

- 1 **Elevated Platform:** Gas fired water heaters located in a garage must be installed on an 18" high platform. Platform must be seismically secured, and any wood in contact with concrete floor must be pressure treated. FVIR may rest on pad 3" above surrounding grade.
- 2 **Seismic Bracing:** In order to prevent the water heater from toppling during an earthquake, it must be secured to the wall in an approved manner. Two straps are required, the strapping must be located at points within the upper one-third and lower one-third of the water heater. The lower strap must be at least 4" above the controls. Strapping must be a minimum of 1" wide and 28 gauge (plumbers tape is OK) and must wrap completely around the water heater then return to the wall. Ends of straps must be secured to a stud with a minimum 1/4" lag bolt with washer.
- 3 **Vent Connector:** That portion of the appliance vent which is within the same room as the appliance. Pipe sections must be secured with sheet metal screws or rivets, minimum of 3 per joint. The rise of the vent connector must be a minimum of 1/4" per foot. Clearance from the vent connector to any combustible construction must be at least 6" for single wall pipe and 1" for double wall pipe.
- 4 **Clearance to Combustibles:** The clearance from the appliance vent to any combustible construction must be at least 1". In order to maintain clearances from combustible insulation in attics, a metal sleeve shall be provided around the vent pipe, extending 6" above insulation and maintaining a minimum of 1" around vent.
- 5 **Vent Termination:** Vents must extend above the roof surface a minimum of 12" and terminate in an approved vent cap. The minimum total height of the venting system is 5' from vent collar to termination. Termination must be a minimum of 4' from any opening into the building and 8' from vertical wall.
Exception: direct vent.
- 6 **Temperature & Pressure Relief Valve & Drain Line:** All water heaters must be equipped with a list temperature and pressure relief valve and drain line. The drain line should be equal to the outlet size, but in no case be less than 3/4" copper or galvanized pipe, and must extend from the valve to the outside of the building. Piping must be strapped. The end of the pipe should not be more than 24" or less than 6" above the ground and pointing downward. If you cannot drain to the outside, other locations for termination may be approved. Discharge into the water heater pan shall be prohibited.
- 7 **Combustion Air:** If the room or area in which the water heater is located has a volume less than 2000 cubic feet, then you may need to provide additional combustion air from outside. Combustion air grills must be located both high and low. They must be installed within the upper 12" and lower 12" of the appliance enclosure or room. Contact the Building Division for the required size of the air grills.
- 8 **Gas Connection:** The gas supply must have a shut off valve adjacent to the water heater. An approved flex connector must be used for the final connection to the water heater, with a maximum length of 36 inches.
- 9 **Non Combustible Collar:** A metal collar shall be placed against the ceiling to seal the gap between the sheetrock and the vent.
- 10 **Pipe Insulation:** 1" thick pipe insulation the first 5' of both cold and hot water inlet and outlet piping must be insulated. Except that the clearance from the vent connector or vent of 6" for single wall and 1" for double wall must be maintained.
- 11 **Pipe Bollard:** If the water heater is located in the path of travel of a vehicle then a protective 3" pipe bollard may be required to be installed so as to protect the water heater from damage. Pipe is to be 3' above floor and set into a 2' deep concrete foundation and filled with concrete.

12 **Appliance Vent:** That portion of the venting system which penetrates the ceiling, floor, attic or roof systems must be of type B, BW, or type L, or other listed assembly approved by the manufacturer. The appliance vent shall extend in a generally vertical direction with offsets not to exceed 45 degrees from the vertical.

13 **Bond the hot and cold water to the gas pipe:** #8 or larger wire is required on any metallic components in the building that could become energized.

14 **Required installation of a carbon monoxide detector outside of bedrooms and on each level.**